

Precaution Notice

Only a technician, authorized by ENERMAX, is allowed to perform maintenance service!
Warranty is subject to void under unauthorized attempt to open the power case or modification of any kinds, even attempted only, of the power supply or its components!

ENERMAX will not be responsible for damages caused by following situations:

- Opening of the PSU case and/or modification of any component or cable without ENERMAX' written authorization
- Ignoring connector's wrong insertion prevention design by attaching a connector to a device in wrong orientation
- Connecting too many devices to one cable unit by using additional adaptor (Y cables) or exceeding ENERMAX Eternity-connector recommendation which may cause voltage drop to the devices and eventually damage them.
- Usage of non-genuine ENERMAX modular cables
- Damage caused by natural phenomena or uncontrollable forces, such as lightning, flooding, fire, earthquake, etc.

This ENERMAX Technology Corporation product is warranted to be free from defects in material and workmanship for a period of three (3) years from the date of purchase. ENERMAX Technology Corporation agrees to repair or replace the product, at its own option and at no charge, if, during the warranty period, it is returned to nearest ENERMAX Technology Corporation subsidiary/agent with all shipping charges prepaid and bearing a return merchandise authorization (RMA) number, and if inspection reveals that the product is defective. Charges for removing or installing the product are excluded under the terms of this warranty agreement. This warranty shall not apply to any product, which has been subject to connection to a faulty power source, alteration, negligence, or accident, or to any product, which has been installed other than in accordance with these instructions. In no event shall ENERMAX Technology Corporation, or its subsidiaries, or agents be liable for damages for a breach of warranty in an amount exceeding the purchase price of this product!

If you are uncertain whether or not your ENERMAX PSU is defective, please contact your dealer/reseller for support!

Web Site: <http://www.enermax.com>

E-mail: enermax@enermax.com.tw

© 2008, ENERMAX Technology Corporation, 15F-2, No. 888, Jing-Guo Road, Taoyuan City (330), Taiwan (R.O.C.), Tel. +886-3-316-1675, Fax. +886-3-346-6640

All rights reserved. Actual product and accessories may differ from Illustrations. Information in this manual is subject to change without prior notice. Printing errors and omissions excepted. All trademarks, registered trademarks and/or product names mentioned are the property of their respective owners.

ENERMAX MODU82+ Series Power Supply Specification

Spec. \ Model	EMD425AWT	EMD525AWT	EMD625AWT			
AC Input						
Input Voltage	100-240VAC, 50-60Hz, automatic switching, Active PFC (Maximum operation range: 90-265VAC)					
Input Current	6.7A-3A	7.5A-3.5A	9.5A-4A			
DC Output						
	Rated	Combined	Rated	Combined	Rated	Combined
+3.3V	0.1-20A	120W	0.1-24A	140W	0.1-24A	140W
+5V	0.1-20A		0.1-24A		0.1-24A	
+12V1	0.1-22A	396W (33A)	0.1-25A	480W (40A)	0.1-25A	600W (50A)
+12V2	0.5-22A		0.5-25A		0.5-25A	
+12V3	0-22A		0-25A		0.0-25A	
-12V	0-0.6A	7.2W	0-0.6A	7.2W	0-0.6A	7.2W
+5Vsb	0-3A	15W	0-3A	15W	0-3A	15W
Total Power	425W		525W		625W	
Protection Circuits						
Over Current Protection	DC Rails		Trigger Range			
	+3.3V		28-40A			
	+5V		28-40A			
	+12V1/2/3		25-30A (425W) / 30-35A (525/625W)			
Over Voltage Protection	DC Rails		Trigger Range			
	+3.3V		3.7 – 4.1V			
	+5V		5.7 – 6.5V			
	+12V1/2/3		13.1 – 14.5V			
(DC) Under Voltage Protection	DC Rails		Trigger Range			
	+3.3V		2.0-2.4V			
	+5V		3.3-3.7V			
	+12V1/2/3		8.5-9.5V			
(AC) Under Voltage Protection	Activated when AC input voltage < 80VAC					
Over Power Protection	Activated when output power > 110~150% of rated max load.					
Short Circuit Protection	Activated when any DC rails short circuited					
Over Temperature Protection	Activated when PSU heat sink > 90-100°C / 194 - 212°F					
Environment						
Temperature	Operation ambient: 0~40°C/32~104°F (for full rated output) Storage ambient: -40~70°C/-40~158°F					
Humidity	Operation: to 85% relative humidity, non-condensing at 25°C/77°F Storage: to 95% relative humidity, non-condensing at 50°C/122°F					
Others						
Power Factor	> 0.97 (Active PFC)					
Efficiency	82%-85% @ 115VAC, 84-88% @ 230VAC (80 PLUS® testing standard)					
Cooling	One 12cm axial fan, 450 – 1500RPM (±10%) @ 25°C ambient; 450-2000RPM(±10%) @ 40°C ambient, speed auto controlled.					
MTBF	> 100,000 hours at 70% of full rated load, 230VAC/50Hz, 25 °C (MIL-HDBK-217F standard)					
Dimension	150 (w) x 86 (h) x 140 (d) mm					
Weight	1.6kg(for 425W) / 1.8kg(for 525W & 625W) (without modular cables)					
Safety	UL/cUL, TUV, BSMI, CCC, GOST, CB					
EMC	CE (EN61204-3 standard), FCC, MIC					

User's Manual

Dear customer,

Thank you for choosing this ENERMAX MODU82+ power supply unit (PSU)! Please read this manual carefully and follow its instructions, before installing the PSU.

We, ENERMAX, are globally renowned as the leading manufacturer of innovative PC products of highest quality just like this MODU82+, which complies with the newest standard for desktop class power supplies. We would like to draw your attention to the fact that PC is a delicate systems, which require very specific conditions to work best for you without failing. To avoid failures and to increase lifetime of your entire PC, we suggest you to make sure that:

- Your PC is NOT located near a radiator or any other heat producing device
- Your PC is NOT located near a magnetic device
- Your PC is NOT located in a moist and/or dusty and/or vibrating environment
- Your PC is NOT exposed to direct sunshine
- Your PC is sufficiently cooled by additional fans

We do not recommend using PC systems with fanless cooling, because a potentially high inner temperature decreases stability and lifetime of all components inside your PC!

COMPATIBILITY

- ENERMAX MODU82+ series is compliant with:
 - Intel ATX12V Power Supply Design Guide v2.3 specification and downward compatible with v2.0, v2.01 and v2.2.
 - ATX System Design Guide v2.2, v2.1
 - BTX/ EEB/ CEB/EPS12V
- This PSU does not support MB with ISA expansion slot, which might require -5V power. -5V has been cancelled from Intel ATX12V v1.3 specification onwards.

EXTRA NOTICE

- If you use multi outlets AC extension cables to provide the system power, do not use other high power consumption equipment, such as laser printers or radiators, on the same extension cable to avoid exceeding cable's safety loading capacity.
- If you plan to add the UPS (Uninterruptible Power Supply) for your system, please choose adequate watts/VA capacity UPS for possible supplied devices need. Ex.

Connected devices to same UPS	Estimated peak power draw (W/VA)
Dual CPU workstation with MODU82+ 525W	640W / 646VA
20" LCD monitor with speaker	55W / 94VA
A4 inkjet Printer	30W / 60VA
Suggest UPS minimum output power capacity: 725W or 800VA	

- Please do not mistake VA capacity as Watts, or use insufficient power UPS. This would result less UPS battery runtime or the inability to power the system in battery mode.
- This PSU is compatible with simulated and pure sine wave UPS.

NAME OF PARTS

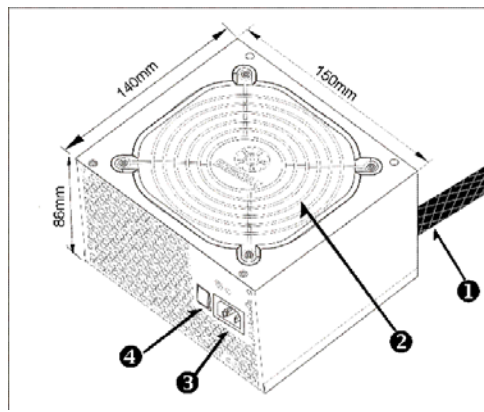

1. Output cable: Please check “Cables & Connectors” section.
2. 12cm fan.
3. AC inlet *
4. I/O switch*: individual PSU on/off switch (I=ON, O=OFF)









* When assemble or maintain the system, please remove AC cord from AC inlet, or turn I/O switch into “O” position.

CABLES & CONNECTORS

All connectors are designed to prevent insertion in wrong orientation. If you cannot easily insert a connector to the power supply or PC devices, please check if you are inserting the connector in the right orientation. Do not try by force to insert it nor modify the connectors. This might damage power supply and PC components, and warranty shall be void.

Use ONLY genuine ENERMAX modular cables coming with ENERMAX PSU. Third party cables might not be compatible and might cause damage to your PSU and/or PC system, and use of third party cable shall void PSU warranty.

● CONNECTOR ON NATIVE CABLE

425W		525W & 625W	
	(20+4)P Mainboard, in combined mode 24-pin configuration supports latest ATX/BTX PC & dual CPU EEB/CEB server/workstation boards.		24P Mainboard 24-pin configuration supports latest ATX/BTX PC & dual CPU EEB/CEB server/workstation boards.
	(20+4)P Mainboard, in split mode 20-pin configuration supports former ATX systems.		
	4+4P CPU +12V, in combined mode 8-pin configuration supports dual CPU server/workstation systems and some single CPU PC systems.		8P CPU +12V 8-pin configuration supports dual CPU server/workstation systems and some single CPU PC systems.
	4+4P CPU +12V, in split mode 4-pin configuration supports most ATX/BTX systems. Please use the connector with “12V” marking.		4P CPU +12V 4-pin connector supports most ATX/BTX systems. Some dual CPU server/workstation might also require this 4-pin connector.
	FM (FAN RPM MONITOR) For 12cm fan RPM detection. Normal fan speed for MODU82+ is 450-2000RPM (±10%)		

- **MODULAR SOCKETS & CABLE**



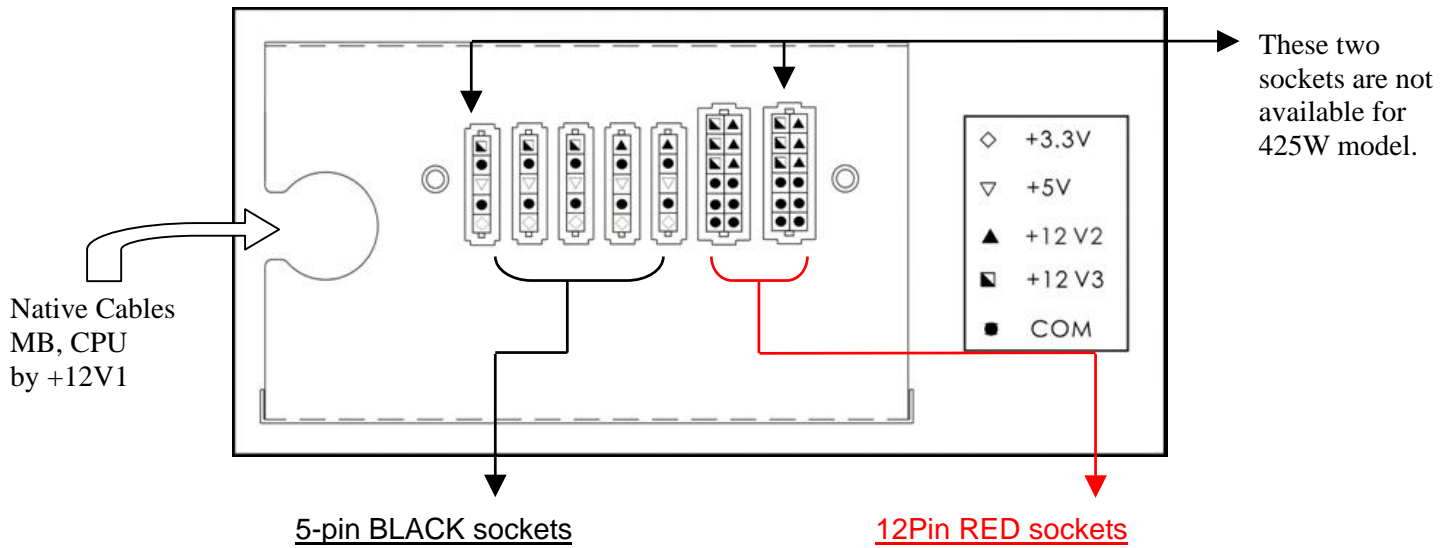

Following graphic illustrates the modular sockets layout and DC rail distribution.



The black sockets are for modular cable to power drives or other peripheral.

The red sockets are for modular cable to power graphics card, CPU or RAM.



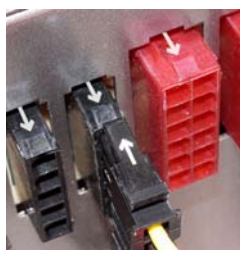
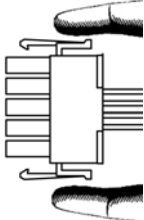

- **MODULAR CABLES SUPPLIED**

	<p>EMC011: 3 X SATA drives Modular cable for SATA drives like ODD and HDD.</p>
	<p>EMC012: 3 x 4P Mole x (IDE/SCSI) drives Modular cable for IDE/SCSI drives and other peripherals</p>
	<p>EMC013: 3 x 4P Mole x (IDE/SCSI) drives + 1 X FDD connector Modular cable for IDE/SCSI drives and peripheral, plus 1 FDD power connector.</p>
	<p>EMC014: 2 x 6+2P (8P) PCI-E 2.0 Modular cable for 1 or 2 performance PCI Express graphic cards, which needs 6P or 8P PCI-E connector.</p>
	<p>EMC015: 1 x 6+2P (8P) PCI-E 2.0 (525W) Modular cable for 1 performance PCI Express graphic cards, which needs 6P or 8P PCI-E connector.</p>

ATTACHING / DETACHING THE MODULAR CABLES

	<p>Attaching the modular cable to PSU 5-pin / 12-pin connector on modular cable and PSU's modular socket has a white arrow mark. The steps to make correct connection is easy:</p> <ol style="list-style-type: none"> 1. Black connector to black socket, and red to red. 2. Arrow mark to arrow mark. 3. Then you can easily plug in the connector.
	<p>Detaching the modular cable from PSU 5-pin / 12-pin connector on modular cable has two hooks to lock with the PSU's modular sockets. When unplug the modular cable from PSU, please press two hooks together and gently pull out the cable.</p>

● CONNECTORS ON MODULAR CABLE

	<p>6+2P (8P) PCI Express, in combined mode 8-pin configuration supports latest extreme graphic cards, which require 8pin PCI-E connector.</p>
	<p>6+2P (8P) PCI Express, in split mode / 6P PCI Express 6-pin configuration supports most performance PCI-E graphic cards, which require 6-pin PCI-E connector.</p>
	<p>SATA For SATA drives. *1</p>
	<p>4P Molex For IDE/SCSI drives or some AGP graphic card with traditional 4P power in socket. *2</p>
	<p>FDD For floppy drive.</p>

*1 Some SATA drives might accept SATA or 4P Molex power. Normally, use either one of power connector to power the driver, BUT NOT BOTH! Please check the drive's manual for details.

*2 Some MB might require this connector to share the +12V current from 20-pin mainboard connector to PCI-E slot. If your MB already supports 24-pin mainboard connector, you may not add the 4P Molex power on it. Please check the MB's manual for details.

BOOTING YOUR SYSTEM

Before booting your system, please check that

1. Main power connector (20 or 24-pin configuration) is properly connected.
2. CPU +12V power connector (4 or 8-pin configuration), and/or a 4P Molex connector (if required by MB) is properly connected.
3. All other needed connectors are properly connected
4. AC cord is properly connected to wall plug and PSU AC inlet.
5. Close your PC chassis
6. Turn on the power supply by switching the I/O switch to “I”, and your system is ready.

PROTECTION, SAFETY & SECURITY

This ENERMAX PSU features multiple protections. In case of most abnormal situations, the power supply will automatically turn off to avoid potential danger to itself and other PC components. It is usually a malfunction of components or user’s negligence to trigger off a protection event. In such circumstance, please check your PC devices and working environment for malfunction:

1. Turn I/O switch of power supply into “O” position, or disconnect AC cord from wall plug and power supply AC inlet.
2. Check PSU for temperature by simply touching it. If it is very hot, this can be caused by malfunction of case fans or the PSU fan itself and/or wrong positioning of your PC.
3. Wait some minutes until PSU cools off
4. Reconnect AC cord to wall plug and power supply AC inlet
5. Turn I/O switch of power supply into “I” position, and reboot your system.
6. Check, if all fans are working
7. Contact technical support of the respective manufacturer of the component which you think might be the cause to the problem (e.g. MB, GPU or PSU)

If you have any question or need support, please contact your reseller or nearest ENERMAX subsidiary/agent or ENERMAX headquarter service center.

Web Site: <http://www.enermax.com>

E-mail: enermax@enermax.com.tw